

## Small, light, powerful – the new MVP<sup>3</sup>

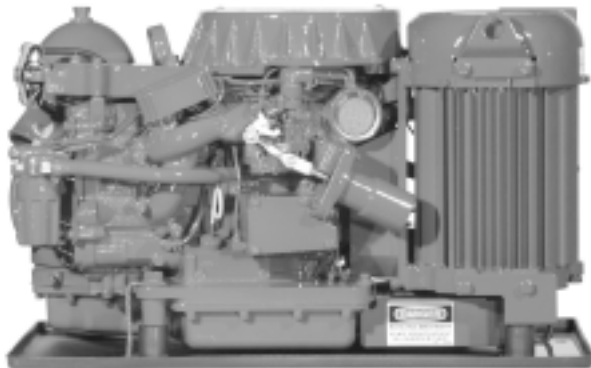

3.0 BPMG Marine Gasoline Generator

### The Most Compact 3.0kW

The 3.0 BPMG nicknamed the “MVP<sup>3</sup>” not only has the smallest envelope available, but there is not another generator like it. The MVP<sup>3</sup> was specifically designed for the small boat owner who previously didn’t have available space to accommodate a generator with “punch”.

### Lightweight & Powerful

Weighing in at only 165 pounds, the MVP<sup>3</sup> weighs less per kW than one would expect. The MVP<sup>3</sup> is powerful enough to run an air conditioner or water heater, etc.

### Smooth & Quiet Operation

Operating with 2-cylinders instead of 1, at a low 2200-rpms instead of 3000 or 3600, and with a specially designed flywheel: the MVP<sup>3</sup> provides smooth performance and doesn’t require a sound shield.

### Simple Installation

The MVP<sup>3</sup> is a simple “plug & play” genset with minimal wiring in the control box. An optional remote start/stop is available with harness to plug into the side of the control box.

### Easy Operation

A simple “one-touch” rocker switch eliminates the need for separate start, stop and priming switch.

### Clean Exhaust

The MVP<sup>3</sup> incorporates a catalytic converter and meets all EPA and CARB requirements.

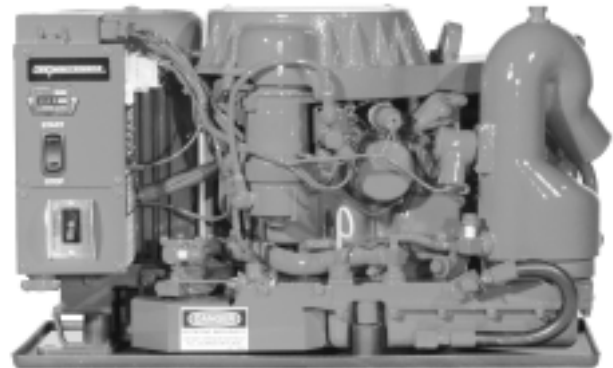

3.0 BPMG Marine Gasoline Generator

### Electronic Governor

Maintains steady speed, provides optimum fuel efficiency and eliminates “bogging down” when load is applied.

### Permanent Magnet Generator

A small, compact and completely sealed permanent magnet generator provides 5% voltage regulation, no-load to full-load, and produces a “utility grade” sine wave.

### Standard Features

- Simple, “one touch” start/stop control panel with running hour meter
- Electronic governing
- Overspeed protection
- Safety shut-downs — overspeed, low oil pressure, high exhaust temperature
- A.C. circuit breaker
- Battery charger
- Water injected exhaust elbow
- Belt-driven, raw water pump
- Vibration mounts
- Lube oil drain hose
- Belt guards
- Operators’ manual and parts list
- “CE” mark
- CARB certified
- EPA certified
- Meets U.S.C.G. regulation 33CFR-183

**Generator Design**

**DESIGN:** Permanent magnet, two-pole.  
**VOLTAGE REGULATION:** Standard +/- 5% no load to full load.  
**FREQUENCY REGULATION:** .5 Hz (1%) no load to full load.  
**INSULATION:** Class "H" as defined by NEMA MG1-1.66.

**TEMPERATURE RISE:** Within NEMA MG1-22.40 operating at full load.  
**COOLING:** Cast centrifugal blower, direct connected.  
**ELECTROMAGNETIC INTERFERENCE LEVEL:** Exceeds requirements for most marine radio-telephones and standard TV's.

Model	Electrical Characteristics					Ratings		Engine	
	Volts	Amps	Hertz	Phase	Wire	Power Factor	KW	RPM	Start
3.0 BPG-612	120	25	60	1	2	1.0	3.0	2200	Remote
3.0 BPG-512	230	13	50	1	2	1.0	3.0	2200	Remote

\* Not field convertible to 50 or 60Hz

**Specifications**

Number of Cylinders	2 Cylinder, horizontal in-line
Type	4 cycle
Displacement	20.0 cu. in. (.33 liter)
Bore and stroke	2.32" x 2.36" (59.0mm x 60.0mm)
Compression ratio	9:1
Rated RPM	2200
HP @ Rated RPM	6.0 HP
Maximum angle of operation	Not to exceed 25° in all directions
Exhaust elbow conn.	2.0" OD (50.8mm)
Raw water conn.	.50" OD (12.7mm)
Dry weight	165 lbs (75 kg)
Combustion system	Semi-spherical type
Aspiration	Naturally aspirated
Lubrication system	Forced pump
Cooling system	Raw water
Full load fuel consumption	.4 GPH (1.5 LPH)
Carburetor	Side draft type
Governor	Electronic
Lube oil filter	Full flow, spin on element
Lubricant capacity	1.5 quarts (1.4 liters)
Fuel transfer pump	Mechanical type

Fuel supply piping	.25" ID (6.35mm)
Starting motor	12 volt, .6kW
Battery charging	11 amps, flywheel alternator
Cold cranking amps	70 amps @ 70 degrees F
Electrical system	12 volts DC, negative ground

**Construction – Engine Components**

Cylinder head	Aluminum
Cylinder block	Aluminum
Crankshaft	Forged crankshaft, two main bearings
Valves	Overhead
Fuel system	Carbureted w/U.S.C.G. approved flame arrestor
Cooling system	Raw water-cooled
Exhaust manifold	Cast aluminum, raw water-cooled

**Optional Equipment**

- Fresh water cooling (heat exchanger)
- Remote start-stop panel
- Ship-shore switch
- Hydro-hush muffler and fittings
- "A" on-board spare parts kit; "B" extended cruising spare parts kit
- Anti-siphon valve for overboard cooling water discharge
- Technical Manual

**Basic Dimensions** inches (millimeters)

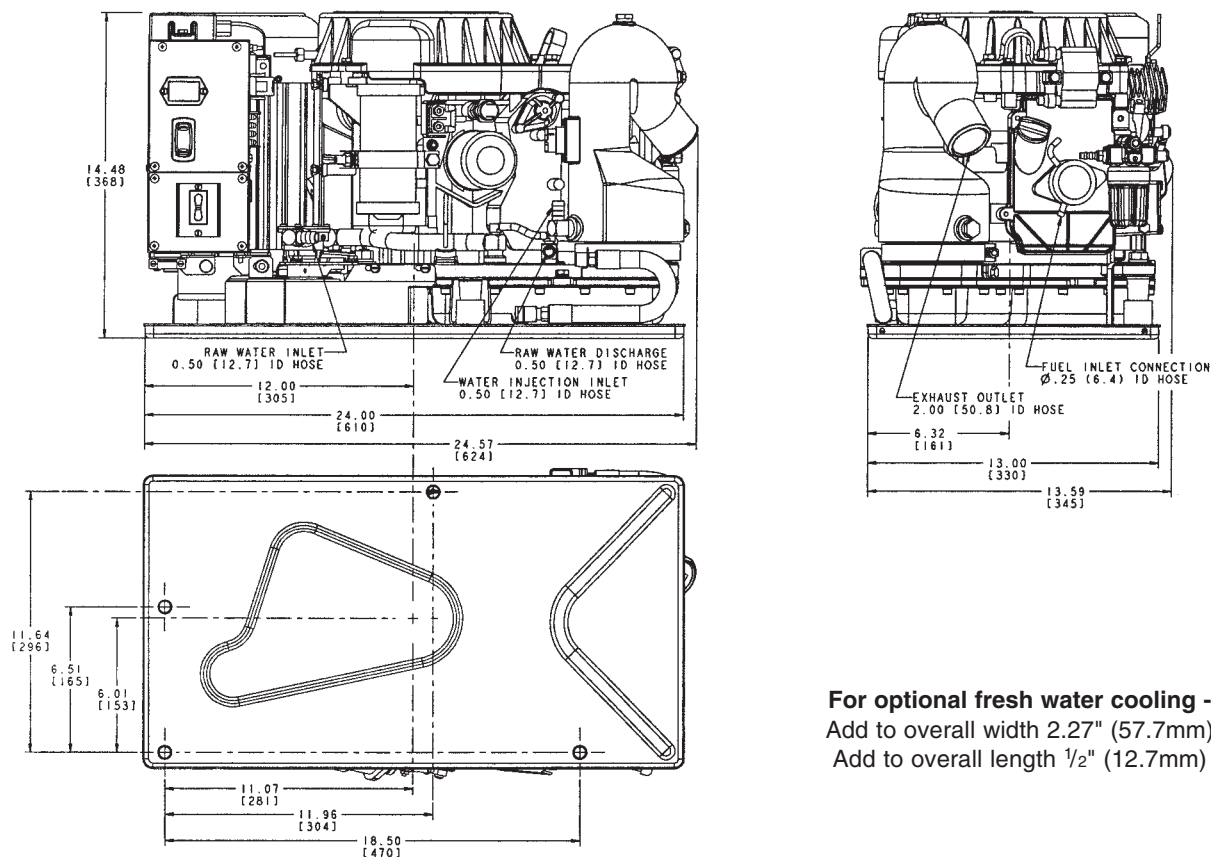

**For optional fresh water cooling -**  
 Add to overall width 2.27" (57.7mm)  
 Add to overall length 1/2" (12.7mm)

Drawings are for reference only and should not be used for installation. Detailed installation drawings are available upon request.